

MMPQ6700
SURFACE MOUNT
COMPLEMENTARY
SILICON QUAD TRANSISTORS

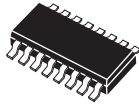

SOIC-16 CASE

Central™
Semiconductor Corp.

DESCRIPTION:

The CENTRAL SEMICONDUCTOR MMPQ6700, consisting of two complementary pairs of transistors, available in the SOIC-16 surface mount package, is designed for general purpose amplifier and switching applications.

MARKING CODE: FULL PART NUMBER

MAXIMUM RATINGS ($T_A=25^\circ\text{C}$)

	SYMBOL		UNITS
Collector-Base Voltage	V_{CBO}	40	V
Collector-Emitter Voltage	V_{CEO}	40	V
Emitter-Base Voltage	V_{EBO}	5.0	V
Continuous Collector Current	I_C	200	mA
Power Dissipation	P_D	1000	mW
Operating and Storage			
Junction Temperature	T_J, T_{stg}	-55 to +150	$^\circ\text{C}$
Thermal Resistance (Total Package)	θ_{JA}	125	$^\circ\text{C/W}$
Thermal Resistance (Each Transistor)	θ_{JA}	240	$^\circ\text{C/W}$

ELECTRICAL CHARACTERISTICS: ($T_A=25^\circ\text{C}$ unless otherwise noted)

SYMBOL	TEST CONDITIONS	MIN	TYP	MAX	UNITS
I_{CBO}	$V_{CB}=30\text{V}$			50	nA
I_{EBO}	$V_{BE}=4.0\text{V}$			50	nA
BV_{CEO}	$I_C=10\text{mA}$	40			V
BV_{CBO}	$I_C=10\mu\text{A}$	40			V
BV_{EBO}	$I_E=10\mu\text{A}$	5.0			V
$V_{CE(SAT)}$	$I_C=10\text{mA}, I_B=1.0\text{mA}$			0.25	V
$V_{BE(SAT)}$	$I_C=10\text{mA}, I_B=1.0\text{mA}$			0.90	V
h_{FE}	$V_{CE}=1.0\text{V}, I_C=0.1\text{mA}$	30			
h_{FE}	$V_{CE}=1.0\text{V}, I_C=1.0\text{mA}$	50			
h_{FE}	$V_{CE}=1.0\text{V}, I_C=10\text{mA}$	70			
f_T	$V_{CE}=20\text{V}, I_C=10\text{mA}, f=100\text{MHz}$	200			MHz
C_{ib}	$V_{EB}=0.5\text{V}, f=1.0\text{kHz}$			10	pF
C_{ob}	$V_{CB}=5.0\text{V}, I_E=0, f=100\text{kHz}$			4.5	pF

R1 (14-November 2002)

SOIC-16 CASE - MECHANICAL OUTLINE

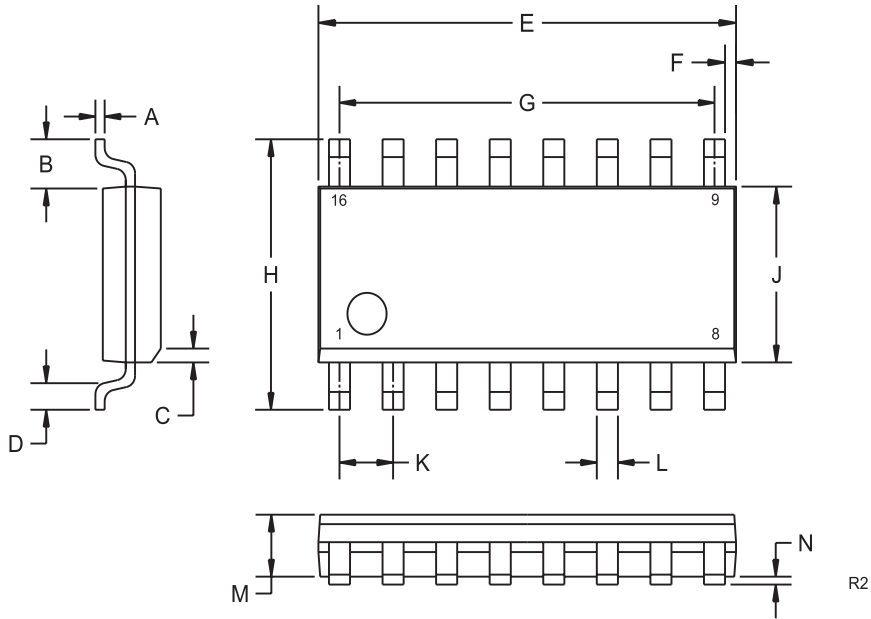

PIN CONFIGURATION

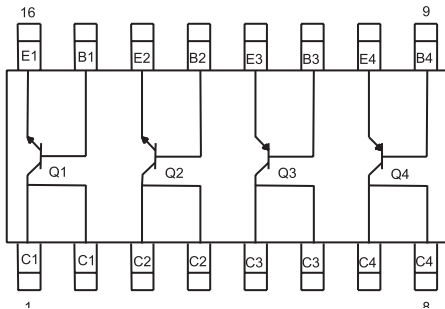

SYMBOL	DIMENSIONS		DIMENSIONS	
	INCHES		MILLIMETERS	
	MIN	MAX	MIN	MAX
A	0.007	0.010	0.19	0.25
B	0.041		1.04	
C	0.010	0.020	0.25	0.50
D	0.020	0.035	0.50	0.90
E	0.386	0.394	9.80	10.00
F	0.010		0.25	
G	0.350		8.89	
H	0.228	0.244	5.80	6.20
J	0.150	0.157	3.80	4.00
K	0.050		1.27	
L	0.0138	0.0201	0.35	0.51
M	0.0531	0.0689	1.35	1.75
N	0.0039	0.0098	0.10	0.25

SOIC-16 (REV:R2)

MARKING CODE: FULL PART NUMBER